

PAN PICK BAR ORDER FILLING STATION

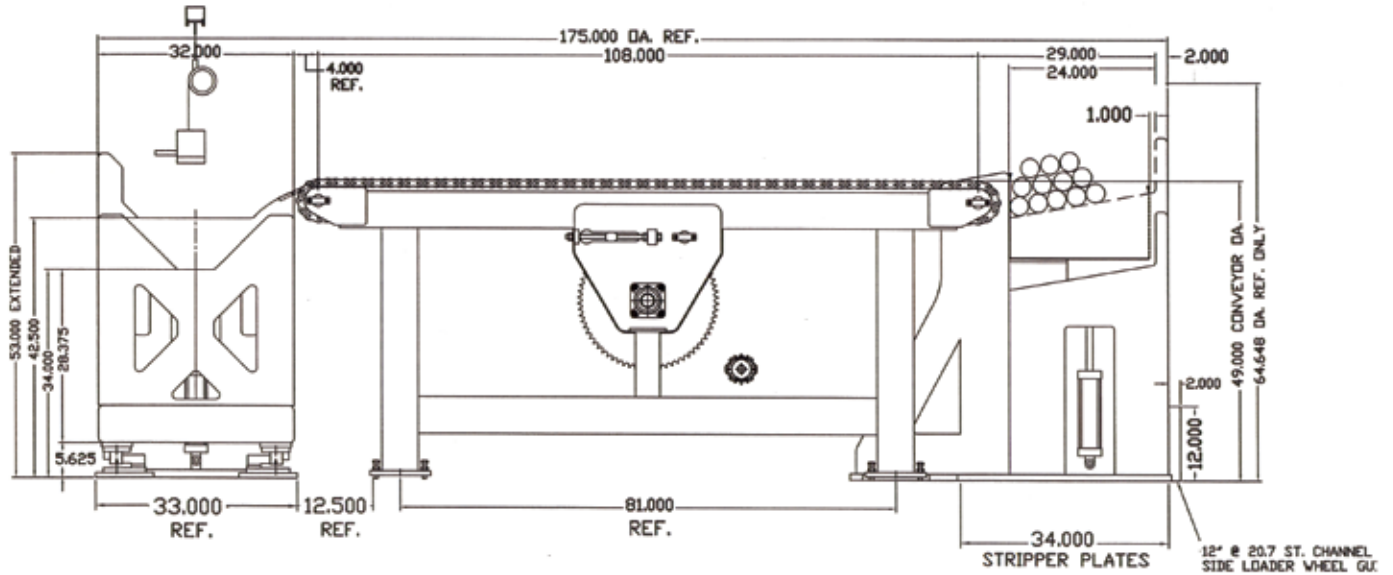

Typical Pan Pick station with accumulation of material for orders feeding impact bars, bundling yokes and packaging station. This provides a buffer between sideloader and packaging increasing productivity

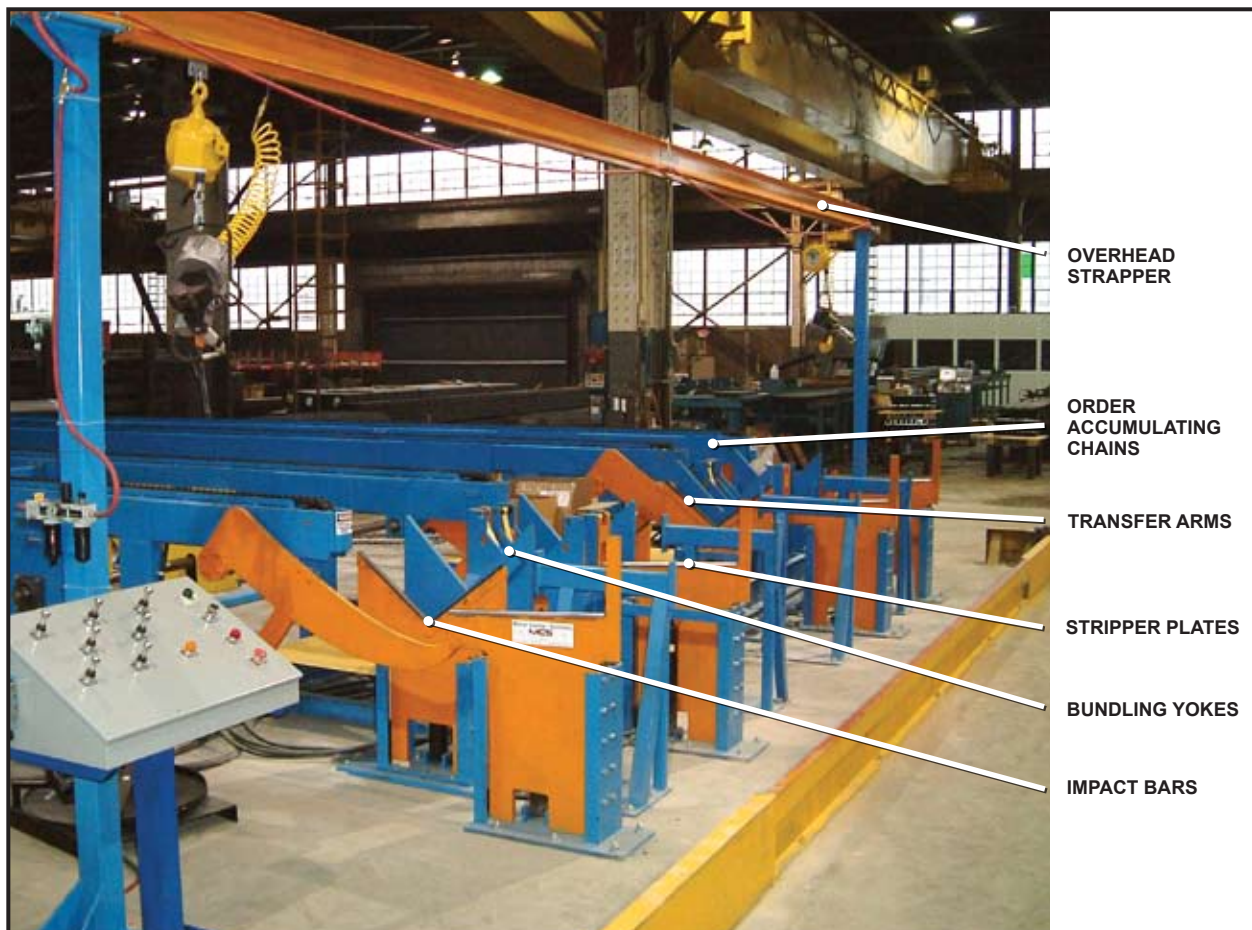

An alternate Pan Pick station with accumulation of finished orders for direct truck loading or transfer to laydown. This provides immediate clearing of the station when an order is finished and is not dependant on crane or fork truck to begin packaging the next order.